

# WELCOME TO CS 16!

## Problem Solving with Computers-I

<https://ucsb-cs16-sp17.github.io/>

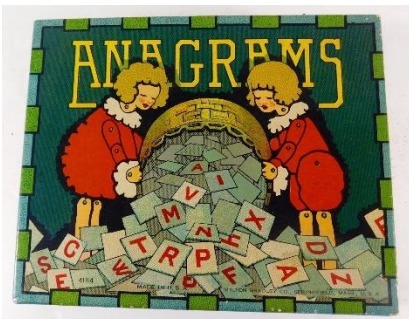

# C++

```

#include <iostream>
using namespace std;

int main(){
  cout<<"Hola Facebook!";
  return 0;
}
  
```



# Instructor

- Diba Mirza ([dimirza@cs.ucsb.edu](mailto:dimirza@cs.ucsb.edu))
  - PhD (Computer Engineering, UCSD)
  - New teaching faculty at the department of Computer Science, UCSB!
  - Before this: Teaching faculty at UCSD for three years
- Office: HFH 1155
- Office hours (starting on Friday 04/07):
  - Tues: 10am-11am, Friday: 9am -10am
  - Or by appointment

# Our teaching staff and brand new tutor program !



Angela Yung  
(UG tutor)



Barbara Korycki  
(UG tutor)

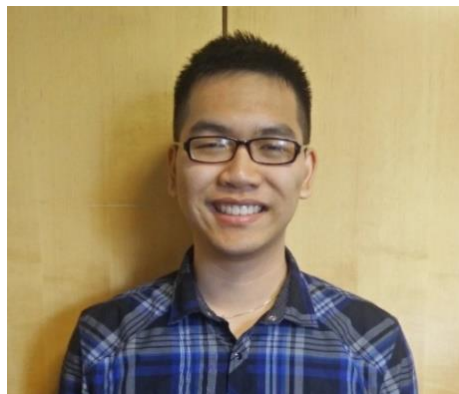

Jimmy Le  
(UG tutor)



Sayali Kakade  
(UG tutor)



Sean Shelton  
(UG tutor)



Steven Fields  
(UG tutor)

Andrew Huang  
(UG tutor)

Bryanna Pham  
(UG tutor)

Natasha Lee  
(UG tutor)

Sherry Li  
(UG tutor)

Shreyas  
Radhakrishnan  
(UG tutor)

Thien Hoang  
(UG tutor)

Clickers out – frequency AB

# About you...

What is your major?

- A. Computer Science
- B. Computer Engineering
- C. Other

# About you...

What is your past programming experience?

- A. Have never programmed.
- B. Have programmed before “just for fun”
- C. Have taken an introductory CS course
- D. I have a lot of programming experience

# Which of the reasons best describes why you are taking this class?

- A. You are a CS/CE major, and will be taking follow up classes
- B. You are NOT a CS/CE major, but are contemplating on switching into CS or CE
- C. Your major requires you to take the class. You are NOT a CS/CE major, are NOT contemplating on switching into CS or CE.
- D. Other - Just curious

# About you...

What is your familiarity/confidence with programming in C++?

- A. Know nothing or almost nothing about it.
- B. Used it a little, beginner level.
- C. Some expertise, lots of gaps though.
- D. Lots of expertise, a few gaps.
- E. Know too much; I have no life.



# About you...

What is your familiarity/confidence with using version control with Subversion, Git or any other VCS?

- A. Know nothing or almost nothing about it.
- B. Used it a little, beginner level.
- C. Some expertise, lots of gaps though.
- D. Lots of expertise, a few gaps.
- E. Know too much; I have no life.

# Have you been in a class that used peer instruction before?

- A. Yes
- B. No
- C. I'm not sure

# Clickers, Peer Instruction, and PI Groups

- Find 1-2 students sitting near you. If you don't have any move.
- Introduce yourself.
- This is your initial PI group (at least for today)

# About this course

# C++

```
#include <iostream>
using namespace std;

int main(){
    cout<<"Hola Facebook!\n";
    return 0;
}
```

## Under the hood of programs

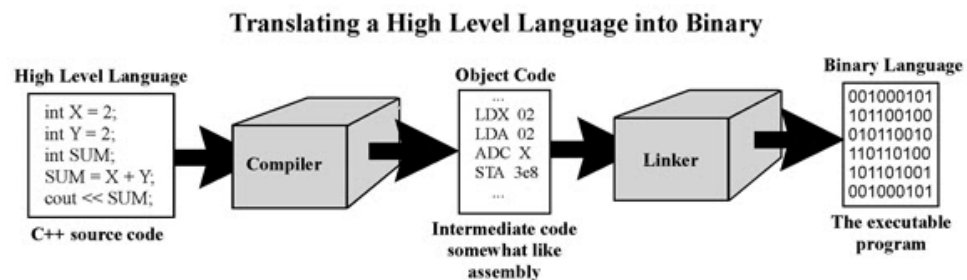

# GitHub



## Solve fun problems!

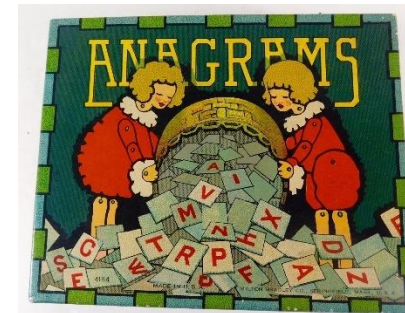

# Why learn C++?



```
#include <iostream>
using namespace std;

int main(){
    cout<<"Hola Facebook!";
    return 0;
}
```

BIG

(Discuss with your group)

- ① Data — fast
- ② Popular (in research & industry)  
↳ Jobs!
- ③ Large scale programs

Which of these reasons is the most important reason to you?

# Why learn what goes on under the hood of programs?

(Discuss with your group)

- ① Debug (correcting an incorrect program)
- ② Gateway to the rest of CS

Which of these reasons is the most important reason to you?

# Why learn github?

(Discuss with your group)

★ Collaboration

★ Managing medium to large wide base  
without going losing your mind

Which of these reasons is the most important reason to you?

# Course website!

<https://ucsb-cs16-sp17.github.io/>

- \* ATTENDENCE in sections and lecture is REQUIRED!
- \* To complete the labs you need a college of engineering account. Send me an email before tomorrow's section if you don't have an account



## iClickers: You must bring them

- Buy an iClicker at the Bookstore
- Register it on GauchoSpace by Friday (01/13)
- Bring your iclicker to class AND section

## Assigned Reading from

- Problem Solving with C++, Walter Savitch, Edition 9

You must **attend** class and lab sections

You must **prepare** for class

You must **participate** in class

# Course Logistics

- Grading

- Class and section participation (iclickers): : 2%
  - Homeworks (due every lecture) : 13%
  - Lab (programming) Assignments(due weekly on Fridays) : 35%
  - Midterm exams: (two, 15% each) : 30%
  - Final exam : 20%
- 
- Less than 75% iClicker response  $\equiv$  missing a class/section
  - No makeups for exams. Make sure you have no scheduling conflicts with exams
  - No LATE submissions unless you have a real emergency!

# Assignment Calendar

Week	S	M	T	W	R	F	S
1	04/02	04/03	04/04	04/05	04/06	04/07	04/08
		<a href="#">h01</a> assigned <a href="#">h02</a> assigned  <a href="#">lect01</a> : Course overview, a gentle intro to C++ - Standard I/O, variables, if-else control structure <b>First day of classes</b>	<a href="#">lab00</a> assigned	<a href="#">lect02</a> : Evaluating C++ expressions, simple flow control- for, while loops, nested and multi-way if-else			
2	04/09	04/10	04/11	04/12	04/13	04/14	04/15
		<a href="#">h01</a> due 02:00pm <a href="#">h02</a> due 02:00pm <a href="#">h03</a> assigned <a href="#">h04</a> assigned  <a href="#">lect03</a> : Nested loops, git, intro to lab01	<a href="#">lab00</a> due 11:59am <a href="#">lab01</a> assigned	<a href="#">lect04</a> : C++ functions and function call mechanics, passing parameters to programs			

- For more information, see our Assignment Calendar: <https://ucsb-cs16-sp17.github.io/info/calendar/>
- All sections will be in PHELPS 3252
- Open labs: CSIL in Harold Frank Hall
- The schedule for sections, office hours and open lab hours is available on our class Google Calendar: <https://ucsb-cs16-sp17.github.io/info/schedule/>

# Basic components of a computer

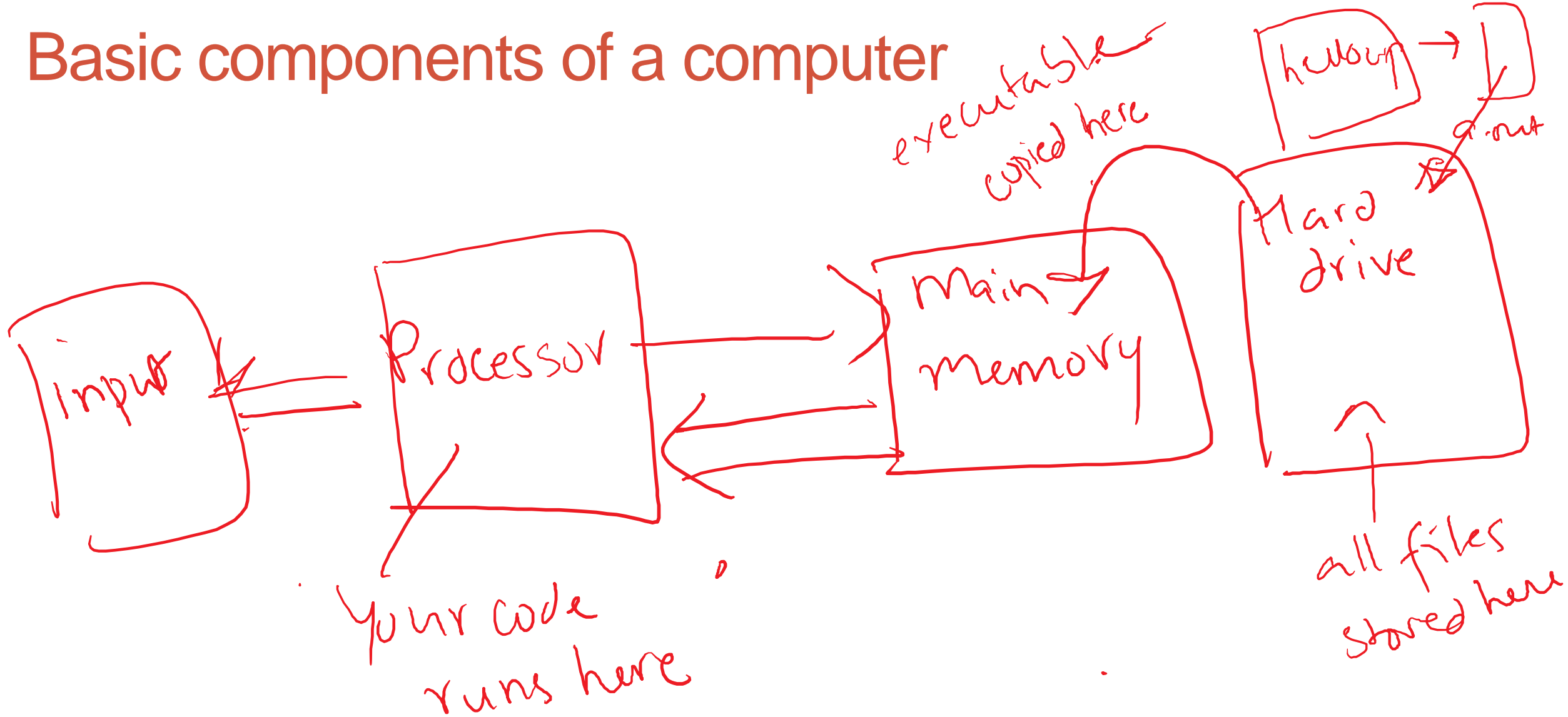

# How do we handle complexity?

```
temp = v[k];  
v[k] = v[k+1];  
v[k+1] = temp;
```

English

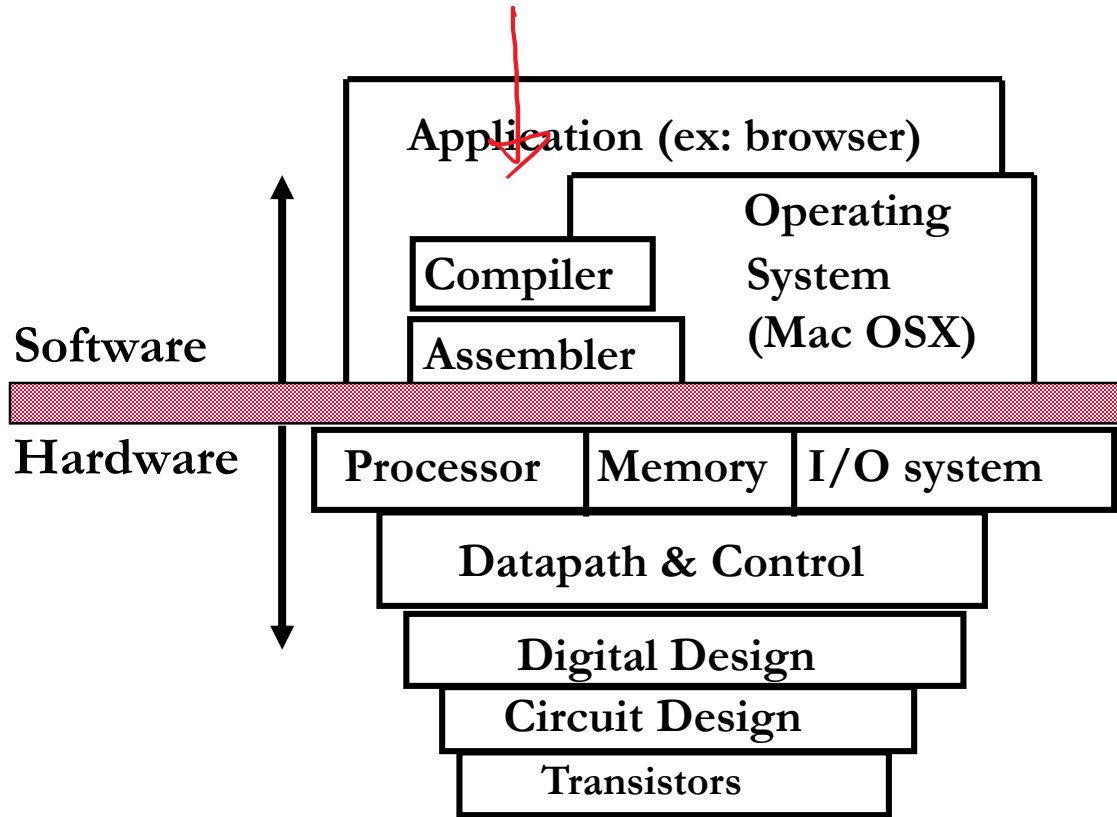

Instruction Set Architecture

0000	1001	1100	0110	1010	1111	0101	1000
1010	1111	0101	1000	0000	1001	1100	0110
1100	0110	1010	1111	0101	1000	0000	1001
0101	1000	0000	1001	1100	0110	1010	1111

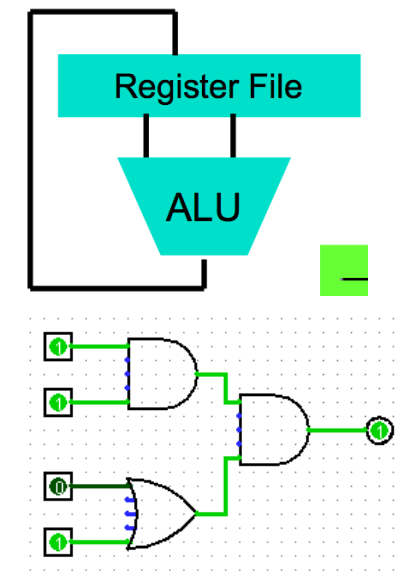

- Big idea: Coordination of many *levels of abstraction*

# Lab 00: Must be done individually

Key learning goals:

- Connect remotely to the CSIL unix servers (csil-0X.cs.ucsb.edu)
- Get familiarized with basic UNIX commands
- Create your first C++ program, compile and run it
- Get started with github
- Let us know if you don't have a CoE account before coming into section

LIVE DEMO



# Next time

- Evaluating C++ expressions
- simple flow control- for, while loops, nested and multi-way if-else